

TC25II/TC30II Series Horizontal CNC Lathe

Characteristics

HISON



- Double row cylindrical roller bearings and high speed thrust angular contact ball bearings are adopted in the front of the spindle, and double row cylindrical roller bearings are adopted in the rear
- 45 ° one-piece casting lathe bed with box way
- Independent tailstock, hydraulic drives sleeve
- 12 station hydraulic turret
- The motor directly drives ball screw, with pre-stretching
- Thin oil lubrication
- Full enclosure

Model	TC25II series	TC30II series
Max. Swing over bed (mm)	Φ560	Φ650
Max. Swing over carriage (mm)	Φ320	Φ420
Max. Turning diameter (mm)	Φ400	Φ500
Max. Bar through spindle (mm)	Φ50 (OptionΦ65)	Φ65 (OptionΦ88)





Machine specification-TC25II series

Model			TC25II×500	TC25II×1000	Model			TC25II×500	TC25II×1000
Scope	Max. swing over bed	mm	Φ560		Tailstock	sleeve diameter	mm	Φ100	
	Max. swing over carriage	mm	Φ320			Quill taper	-	MT.NO.04	
	Max. turning diameter	mm	Φ400			sleeve travels	mm	120	
	Max. turning length	mm	548	1000		Tailstock travels	mm	410	730
	Spindle center to floor	mm	980			Turret	Turret	-	hydraulic V12
Spindle	Spindle speed	rpm	4500		Tool size (OD turning)		mm	25×25	
	Power (continuous/15min)	kW	11/15		Tool size (ID turning)		mm	Φ40	
	Torque (continuous/15min)	Nm	140/250		Index time (one tool)		s	0.55	
	Spindle nose	-	JISA2-6		Power capacity		kVA	25	
	Spindle bore	mm	Φ62 (Op.Φ76)		Coolant Tank		L	200	250
	Max. Bar through spindle	mm	Φ50 (Op.Φ65)		Machine weight		T	4.6	4.9
	Chuck size	Inch	8 (Op.10)		Controller		-	FANUC 0i-TF (TYPE 5)	
Servo axis	X/Z travels	mm	210/610	210/1050	Machine size		mm	4200×2050×1900	4600×2050×1900
	X/Z rapids	m/min	24/30						
	X/Z servo motor power	kW	1.8/1.8						
	X/Z position accuracy	mm	0.008/0.010	0.008/0.012					
	X/Z repeatability	mm	0.005/0.006	0.005/0.008					

Machine specification-TC30II series



Model			TC30II×500	TC30II×1000	TC30II×1500	Model			TC30II×500	TC30II×1000	TC30II×1500
Scope	Max. swing over bed	mm	Φ650			Tailstock	sleeve diameter	mm	Φ100		
	Max. swing over carriage	mm	Φ420				Quill taper	-	MT.NO.05		
	Max. Turning diameter	mm	Φ500				Sleeve travel	mm	120		
	Max. turning length	mm	500	1000	1490		Tail stock travel	mm	370	730	1100
	Spindle center to floor	mm	1030			Turret	Turret	-	Hydraulic V12		
Spindle	Spindle speed	rpm	3500				Tool size (OD turning)	mm	25×25		
	Power (continuous/15min)	kW	15/18.5				Tool size (ID turning)	mm	Φ40		
	Torque (continuous/15min)	Nm	245/400				Index time	s	0.58		
	Spindle nose	-	JISA2-8			Power capacity	kVA	30			
	Spindle bore	mm	Φ76 (OptionΦ102)			Coolant Tank	L	200	250		
Max. Bar through spindle	mm	Φ65 (OptionΦ88)			Machine weight	T	5	5.3	7.3		
Chuck size	Inch	10 (Option12)			Controller	-	FANUC 0i-TF (TYPE 5)				
Servo axis	X/Z travels	mm	260/580	260/1050	260/1550	Machine size	mm	4200×2050×2020	4600×2050×2050	5350×2050×2050	
	X/Z rapids	m/min	16/20								
	X/Z servo motor power	kW	2.5/2.5								
	X/Z position accuracy	mm	0.008/0.010	0.008/0.012	0.008/0.015						
	X/Z repeatability	mm	0.005/0.006	0.005/0.008	0.005/0.010						

45 ° slant bed



Model			TC25II×500	TC25II×1000	TC30II×500	TC30II×1000	TC30II×1500	
Z axis	Box guideway span A	mm					180	
	Tailstock guideway span B	mm					110	

Flat bed (common)

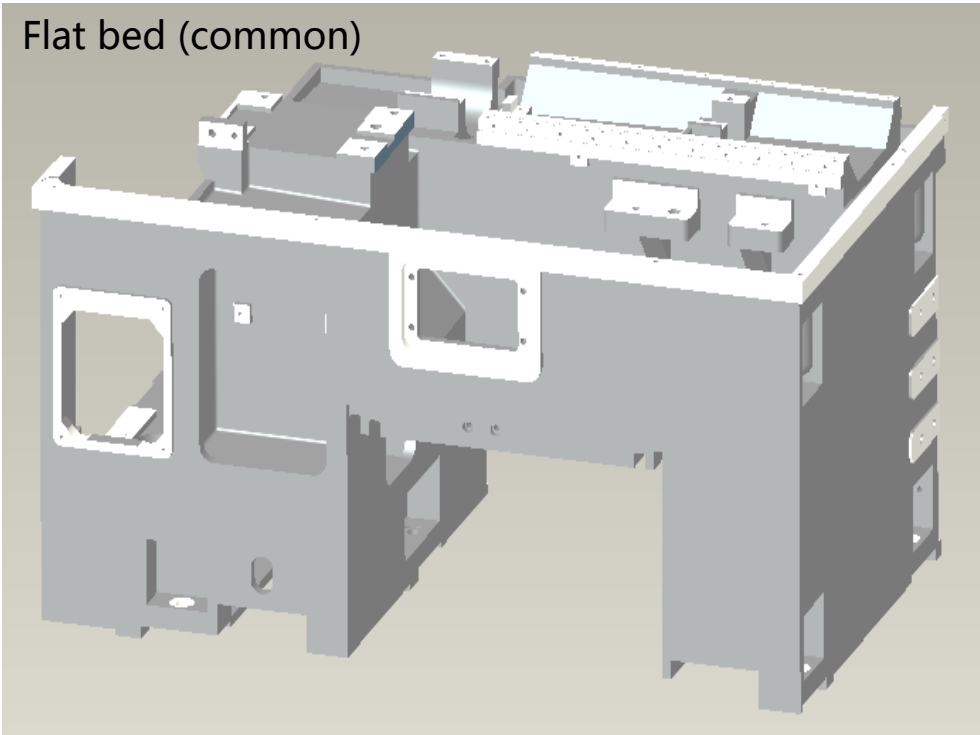

One-piece casting bed - high rigidity
45 ° slant bed – convenient chip removal

One-piece casting slant bed (TC25II/TC30II)

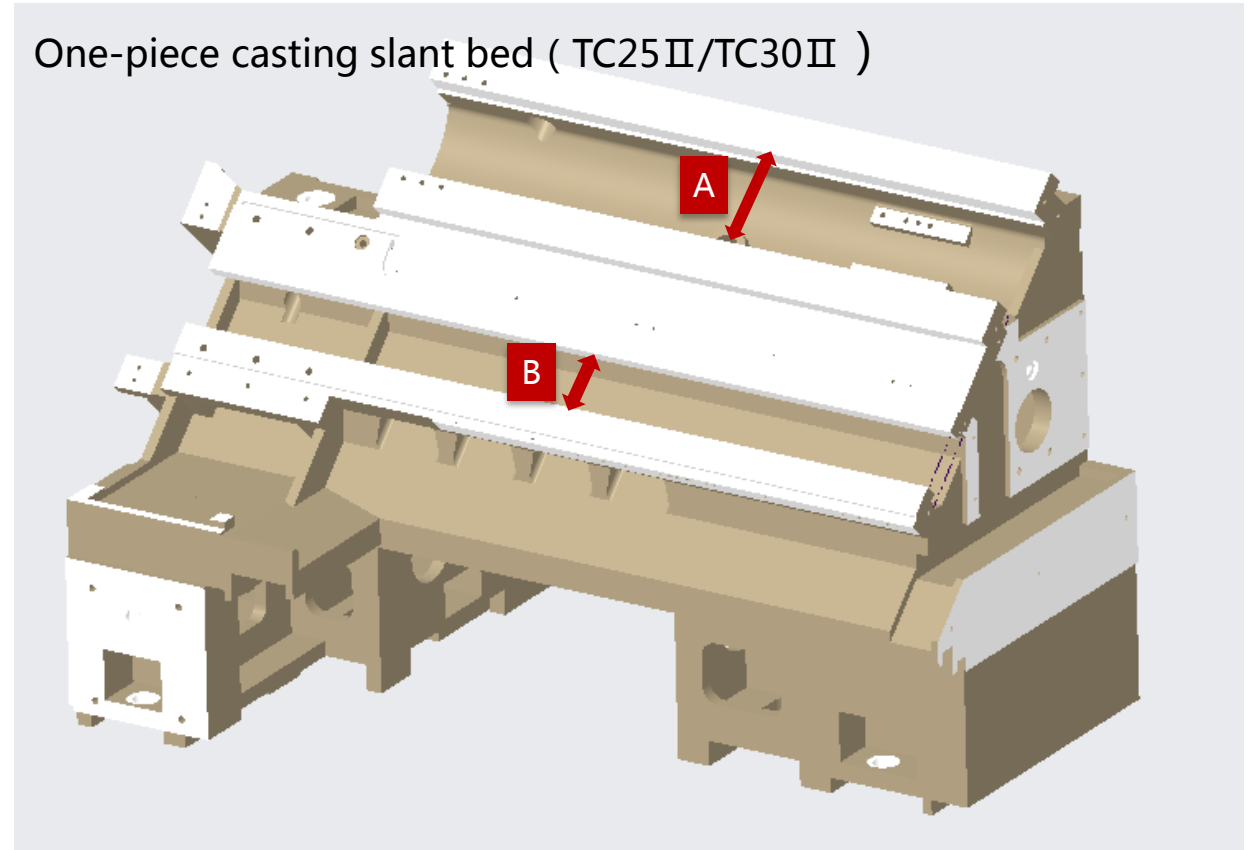

Processing range-TC25II series

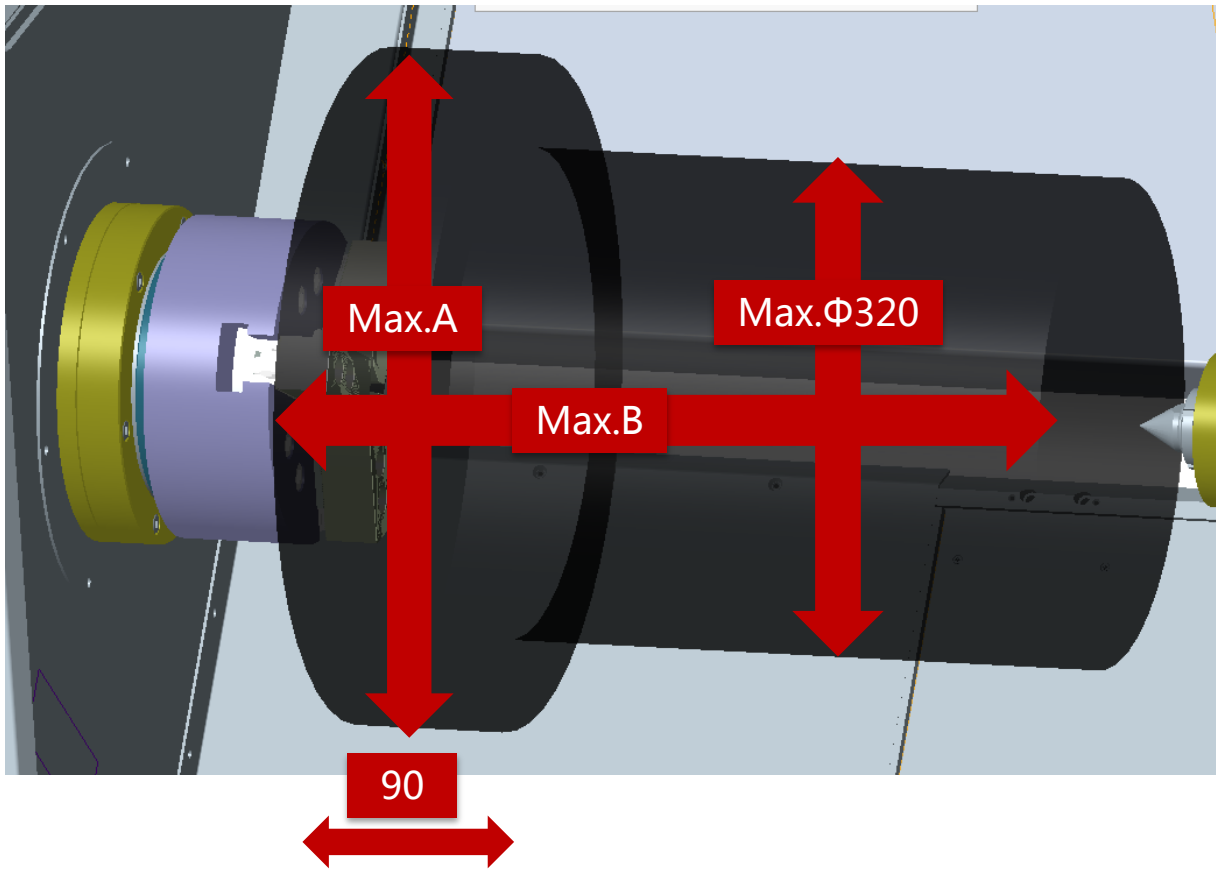

Model	chuck size (inch)	Max. turning diameter A (mm)	Max. turning length B (mm)
TC25II × 500	8	Φ400	548
	8 (hollow)		545
	10 (solid)		531
	10 (hollow)		523
TC25II × 1000	8		1000
	8 (hollow)		997
	10 (solid)		983
	10 (hollow)		975

Notes: maximum turning diameter: the cylindrical axial machining of the cutter does not exceed the cutter head; The maximum turning length starts from the jaw surface

Processing range-TC30II series

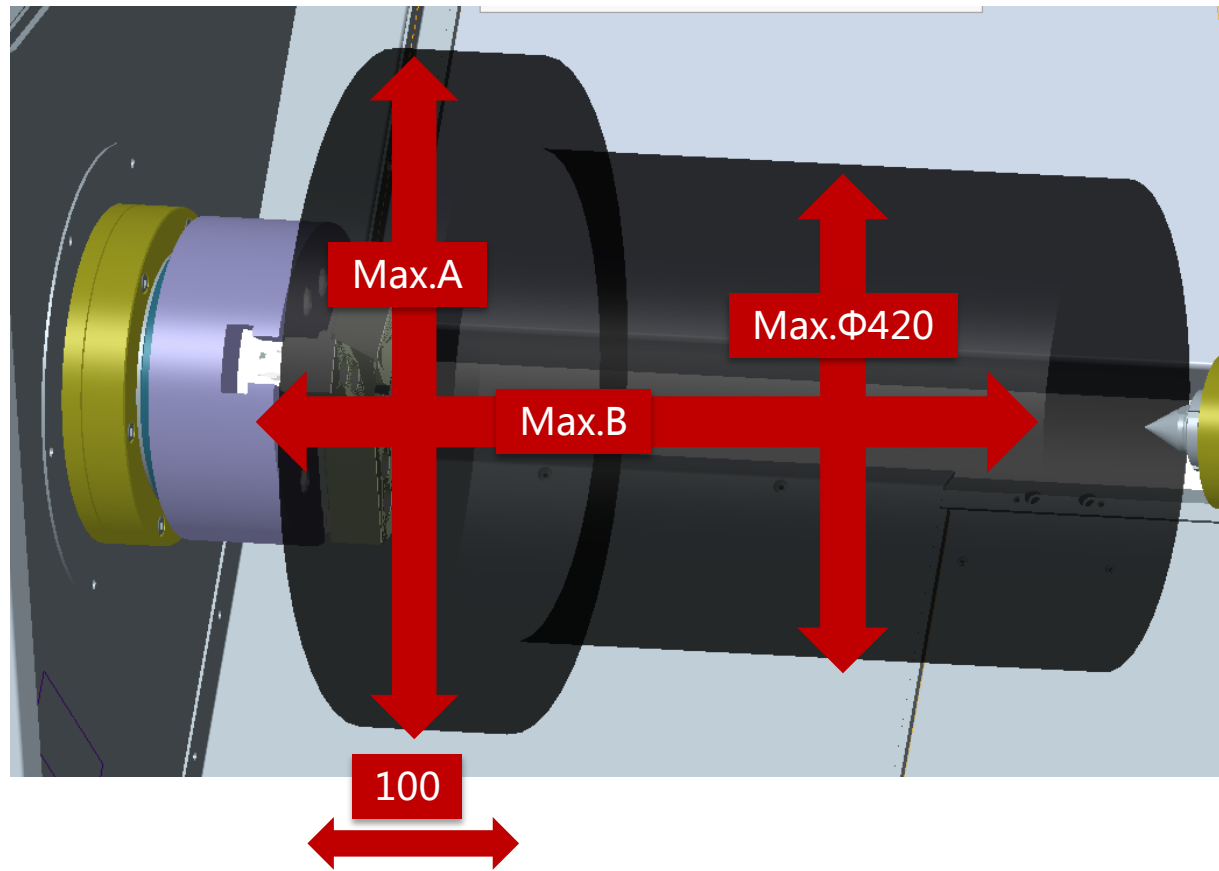

Notes: maximum turning diameter: the cylindrical axial machining of the cutter does not exceed the cutter head; The maximum turning length starts from the jaw surface

Model	chuck size (inch)	Max. turning diameterA (mm)	Max. turning lengthB (mm)
TC30II × 500	10	Φ500	500
	10 (hollow)		492
	12 (solid)		476
	12 (hollow)		475
TC30II × 1000	10		1000
	10 (hollow)		992
	12 (solid)		976
	12 (hollow)		975
TC30II × 1500	10		1490
	10 (hollow)		1482
	12 (solid)		1466
	12 (hollow)		1465

Spindle parameter-TC25II series

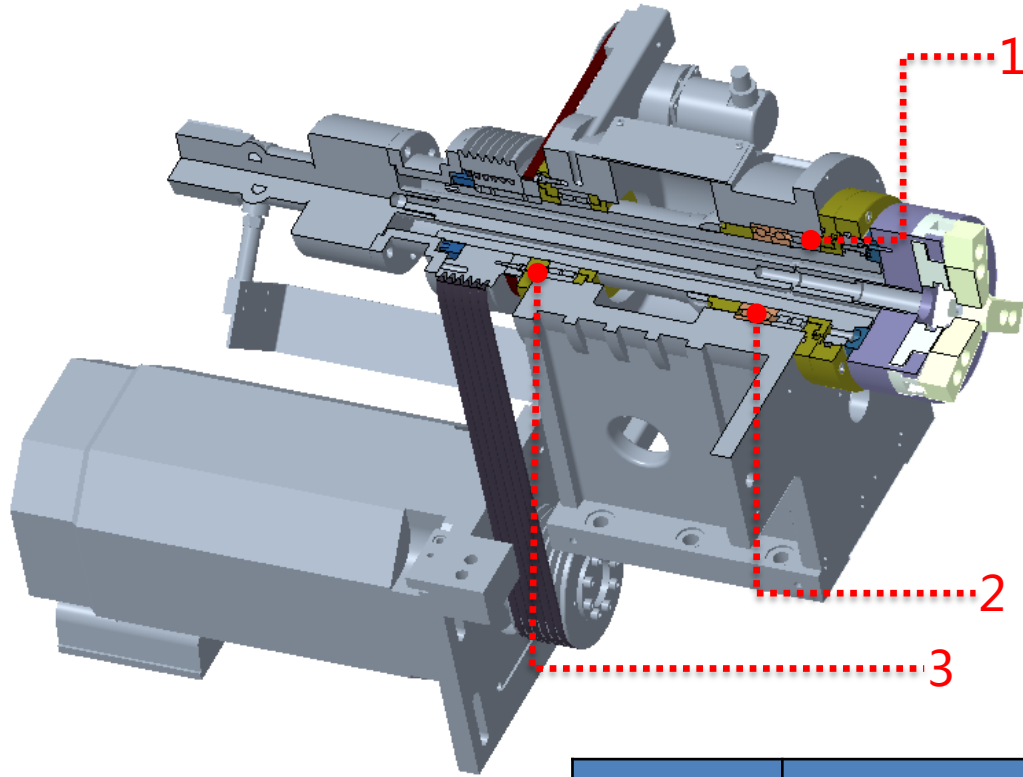

Spindle speed : 4500rpm

Spindle power : 15kW

Spindle torque : 250Nm

No	bearing	brand	accuracy class	Inner diameter(mm)
1	Double row cylindrical roller bearings (front)	NSK	P4	100
2	High speed thrust angular contact ball bearings (front)		P4	100
3	Double row cylindrical roller bearings (rear)		P5	90

Model	Chuck size (inch)	Spindle speed (rpm)	Spindle power (Continuous/15min , kW)	Spindle torque (Continuous/15min , Nm)
TC25II series	8	4500	11/15	140/250
	8 (hollow)	4500		
	10 (solid)	4000		
	10 (hollow)	4200		

Spindle parameter-TC30II series

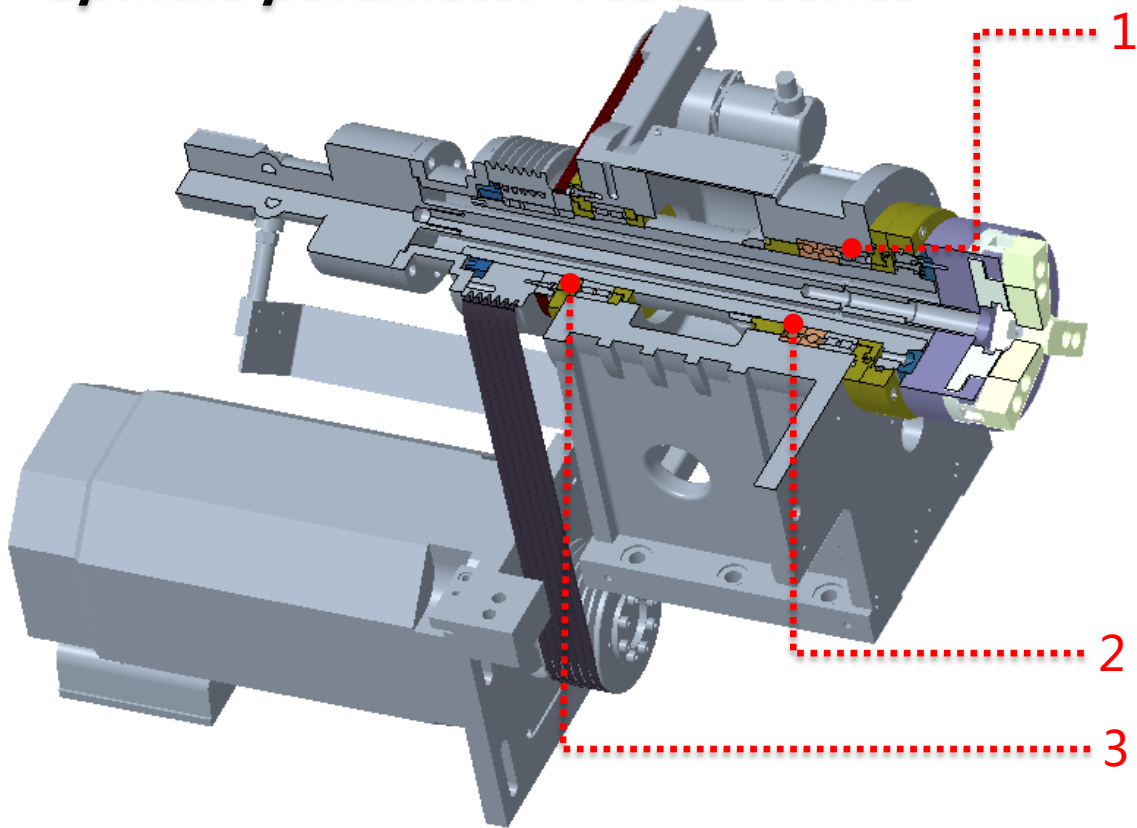

Spindle speed : 3500rpm

Spindle power : 18.5kw

Spindle torque : 400Nm

No	bearing	brand	accuracy class	Inner diameter(mm)
1	Double row cylindrical roller bearings (front)	NSK	P4	120
2	High speed thrust angular contact ball bearings (front)		P4	120
3	Double row cylindrical roller bearings (rear)		P5	110

Model	Chuck size (inch)	Spindle speed (rpm)	Spindle power (Continuous/15min , kW)	Spindle torque (Continuous/15min , Nm)
TC30II series	10	3500	15/18.5	245/400
	10 (hollow)	3500		
	12 (solid)	3300		
	12 (hollow)	3300		

Bar through spindle parameter-TC25II series

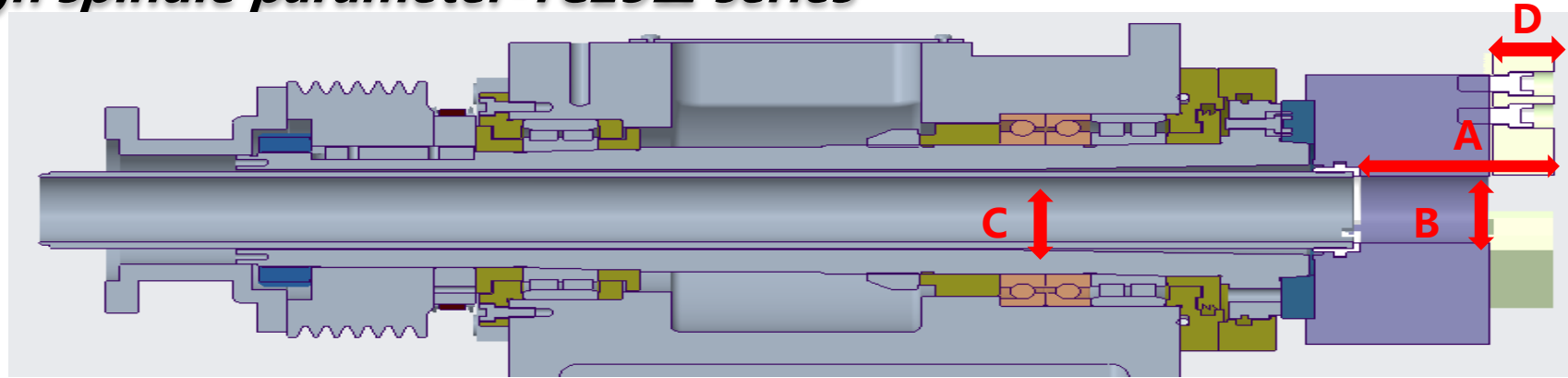

Notes: Only hollow chuck/hollow cylinder is available

Model	Item	workpiece insert length A(mm)	chuck center hole diameter B(mm)	Max. bar through spindle diameter C(mm)	thickness of jaw D(mm)
TC25II series	8" solid hydraulic chuck with solid cylinder (STD)	41	0	0	41
	8" hollow hydraulic chuck with hollow cylinder (OP)	89	Φ52	Φ50	38
	8" hollow hydraulic chuck with solid cylinder (OP)	89	Φ52	0	38
	10" solid hydraulic chuck with solid cylinder (OP)	46	0	0	46
	10" hollow hydraulic chuck with hollow cylinder (OP)	104.5	Φ75	Φ50	43
	10" hollow hydraulic chuck with solid cylinder (OP)	104.5	Φ75	0	43

Bar through spindle parameter-TC30II series

HISON

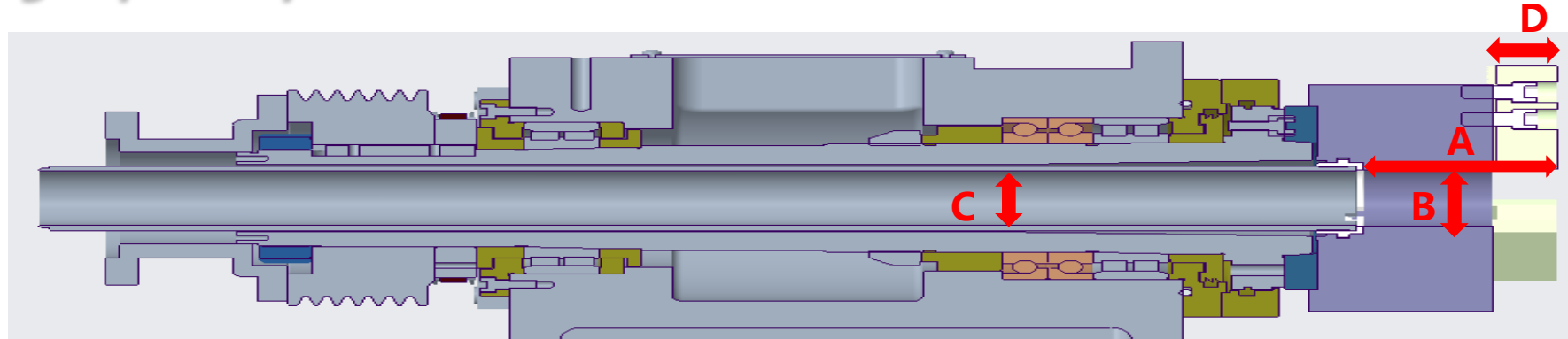

Notes: Only hollow chuck/hollow cylinder is available

Model	Item	workpiece insert length A(mm)	chuck center hole diameter B(mm)	Max. bar through spindle diameter C(mm)	thickness of jaw D(mm)
TC30II Series	10" solid hydraulic chuck with solid cylinder (STD)	46	0	0	46
	10" hollow hydraulic chuck with hollow cylinder (OP)	104.5	Φ75	Φ65	43
	10" hollow hydraulic chuck with solid cylinder (OP)	104.5	Φ75	0	43
	12" solid hydraulic chuck with solid cylinder (OP)	54	0	0	54
	12" hollow hydraulic chuck with hollow cylinder (OP)	119	Φ91	Φ65	51
	12" hollow hydraulic chuck with solid cylinder (OP)	119	Φ91	0	51



Notes: Only hollow chuck/hollow cylinder is available

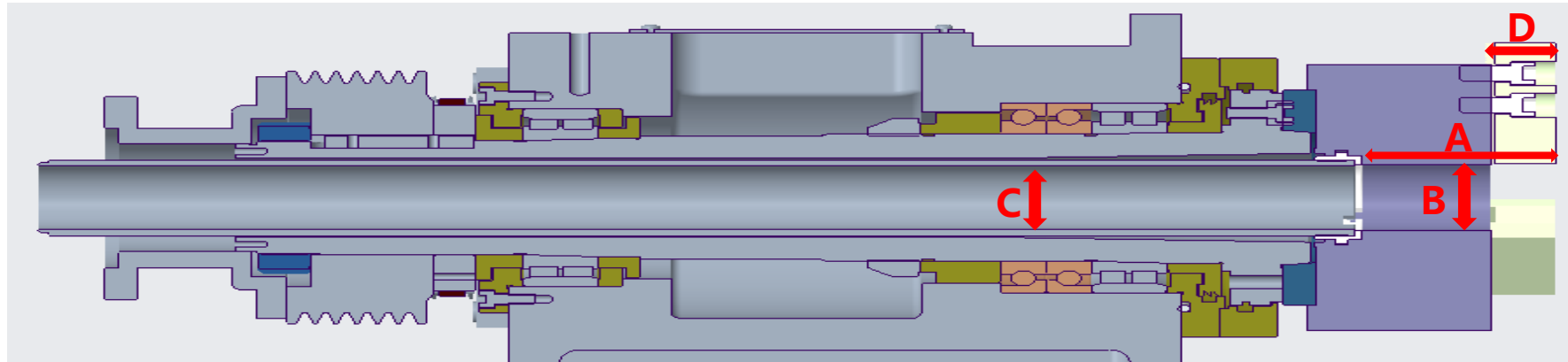

Model	Item	workpiece insert length A(mm)	chuck center hole diameter B(mm)	Max. bar through spindle diameter C(mm)	thickness of jaw D(mm)
TC25II series	8" solid hydraulic chuck with solid cylinder (ST)	41	0	0	41
	10" hollow hydraulic chuck with hollow cylinde (OP)	104.5	Φ75	Φ65	43
TC30II series	10" solid hydraulic chuck with solid cylinde (ST)	46	0	0	46
	12" hollow hydraulic chuck with hollow cylinde (OP)	119	Φ91	Φ88	51



Tool system

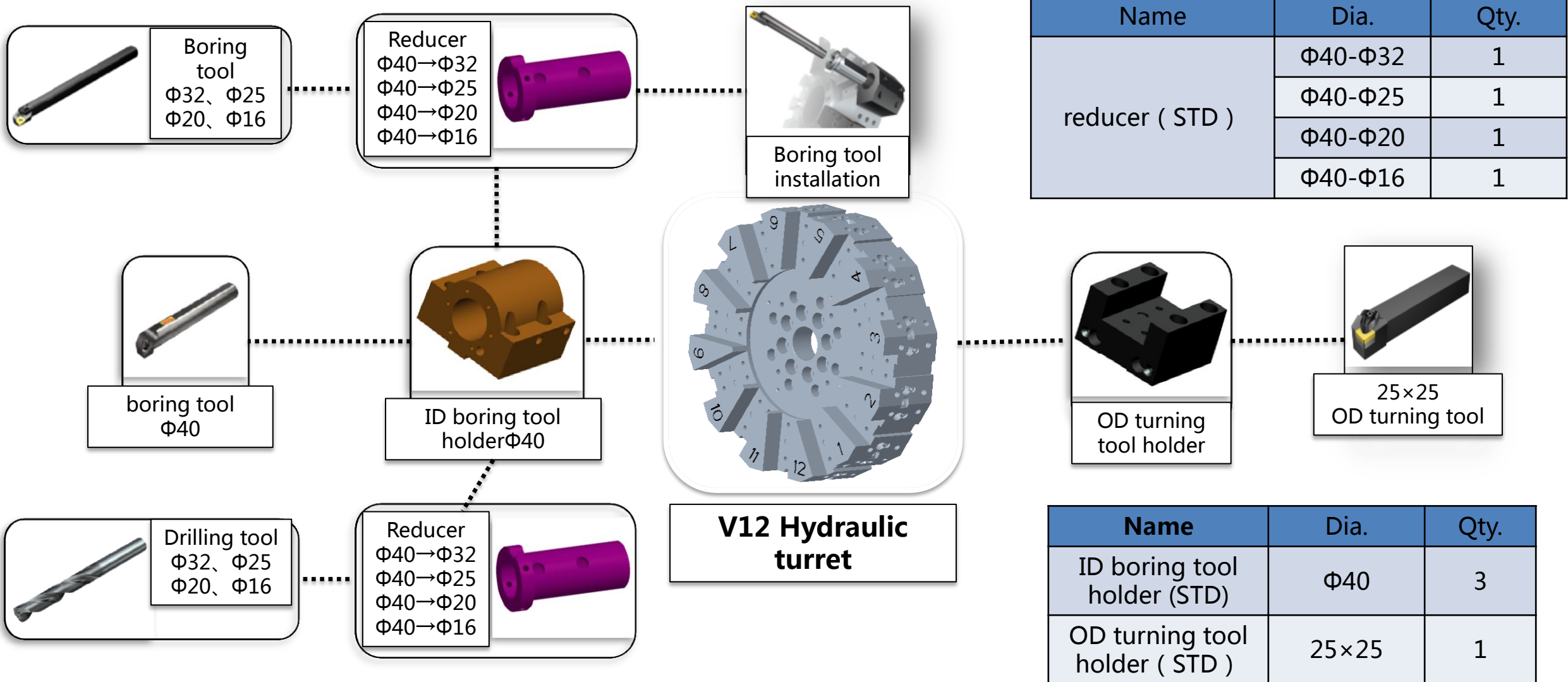

Tailstock parameter

Dead center+ live quill (option)

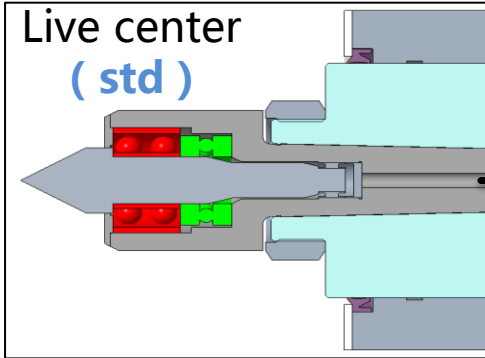
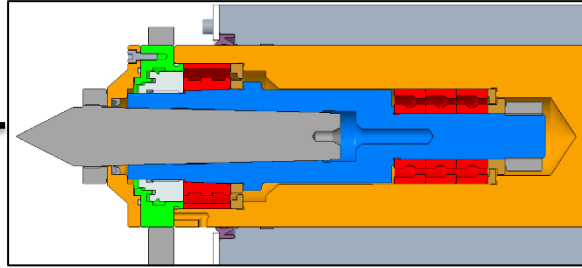

Programmable (option)

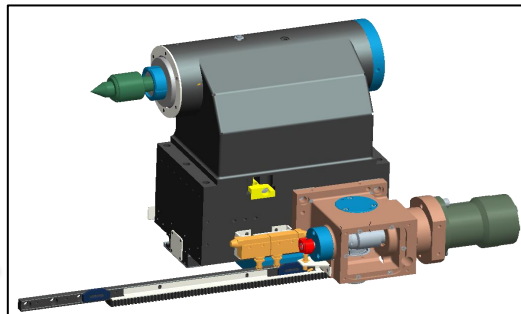

The condition of Max. clamping workpiece weight :

1. The workpiece must be regular and balanced in quality
2. The center of gravity of workpiece must be on the axis of the part
3. The data is only for reference



Item	unit	TC25II series	TC30II series
Quill diameter	mm	Φ100	
Quill travel	mm	120	
Quill bore taper	-	MT.NO.4	MT.NO.5
STD	-	Live center	

Item	-	Suitable for
Live center	STD	Light/medium load
Dead center+ live quill	OP	Super heavy load
Programmable		1. ONE set-up: end surface and OD or ID processing 2. different workpiece length 3. Automatic production

Model	Unit	Max. clamping workpiece weight (std chuck, max. speed)	
		Chuck + tailstock	Chuck (maximum speed)
TC25II × 500	kg	100	23
TC25II × 1000		100	
TC30II × 500		150	39
TC30II × 1000		150	
TC30II × 1500			

Tailstock

Tailstock movement

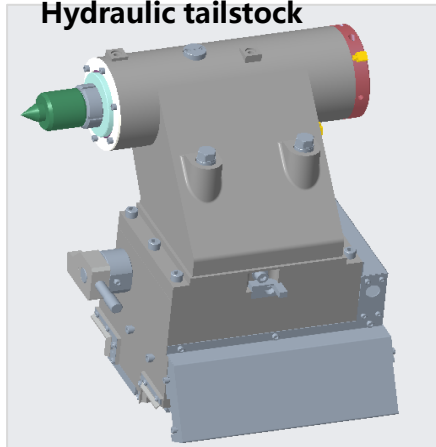

Hydraulic tailstock

Tailstock moves by turret

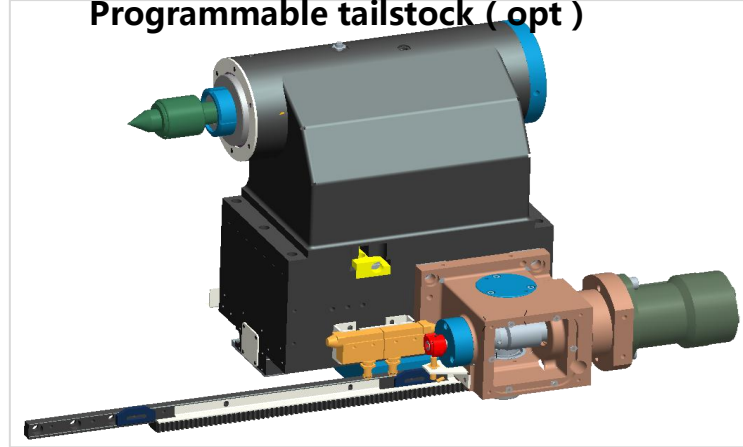

Programmable tailstock (opt)

Hydraulic motor drives tailstock

Quill

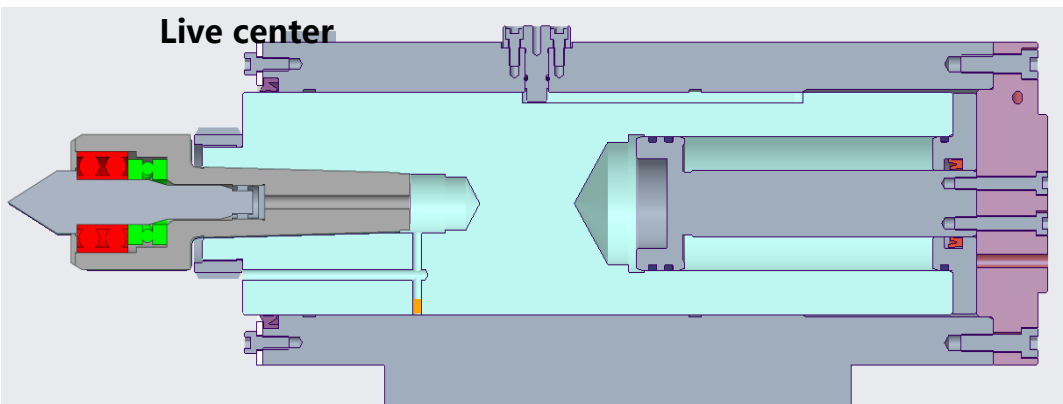

Live center

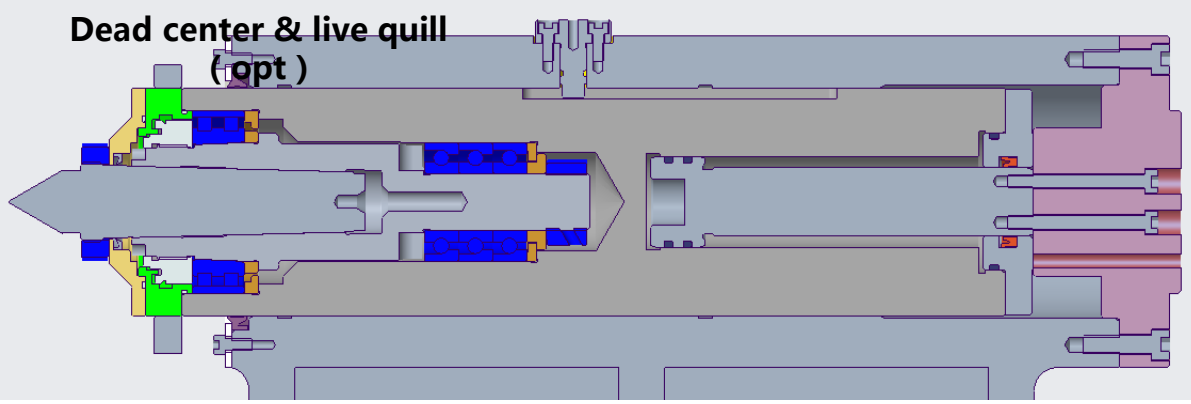

Dead center & live quill (opt)

Programmable Tailstock

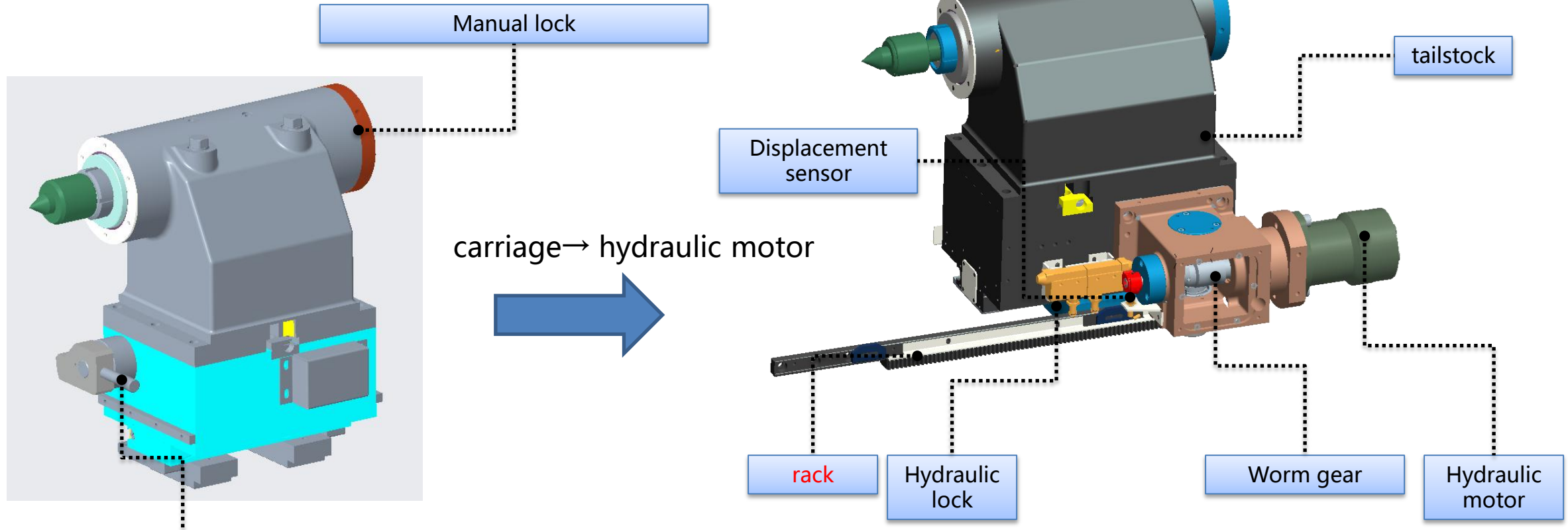

Programmable tailstock parameter					
model	TC25Ⅱ×500	TC25Ⅱ×1000	TC30Ⅱ×500	TC30Ⅱ×1000	TC30Ⅱ×1500
tailstock travels (mm)	410	730	370	730	1100
Rapids (m/min)	9				

X/Z axis parameter

Model			TC25II×500	TC25II×1000	TC30II×500	TC30II×1000	TC30II×1500
X	travels	mm	210		260		
	rapids	m/min	24		16		
Z	travels	mm	610	1050	260	1050	1550
	rapids	m/min	30		20		

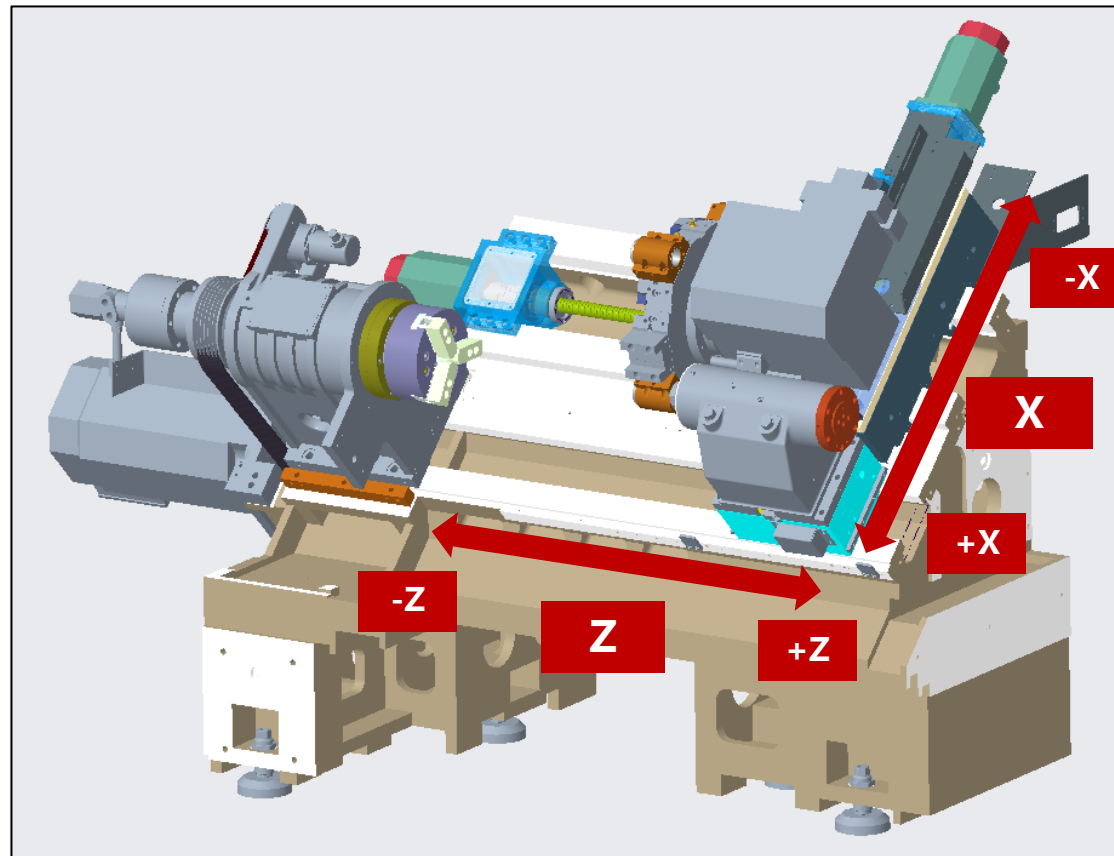

X/Z axis parameter

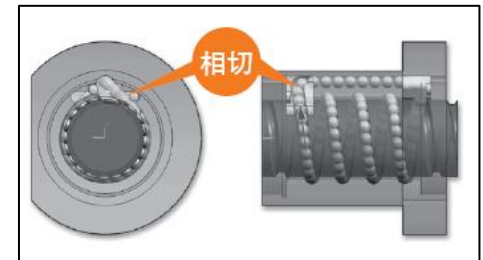
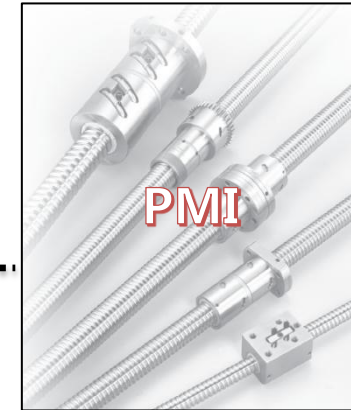
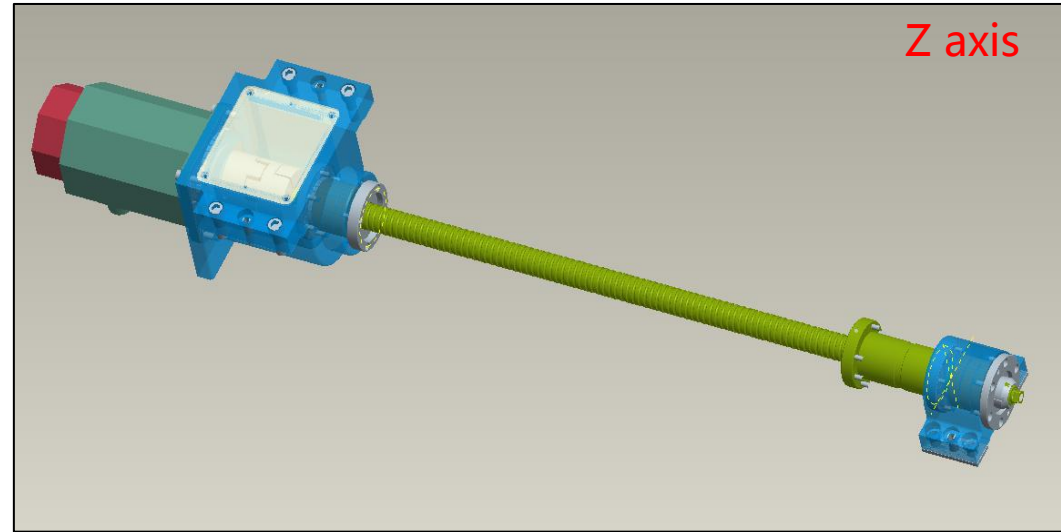
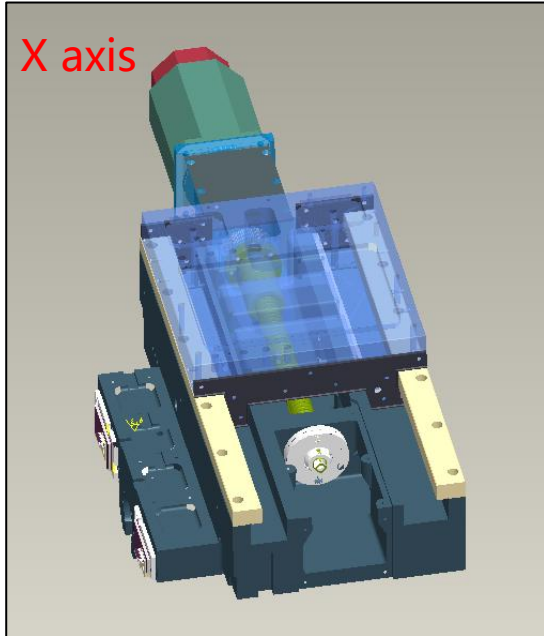

Model	Axis	Brand	Ball screw size(mm)		rated load (kN)		accuracy class
			Dia	lead	rated dynamic load	rated static load	
TC25II/TC30II series	X	PMI	Φ32	8	3900	10930	C3
	Z			10	3890	10910	

MC function - parameter



Item			TC30II MC×500	TC30II MC×1000	TC30II MC×1500	Item		TC30II MC×500	TC30II MC×1000	TC30II MC×1500	
Scope	Max. swing over bed	mm	Φ650			Tail stock	sleeve diameter	mm	Φ100		
	Max. swing over carriage	mm	Φ420				Quill taper	-	MT.NO.05		
	Max. turning diameter	mm	Φ450				sleeve travels	mm	120		
	Max. turning length	mm	450	920	1410		Tailstock travels	mm	370	730	1050
	Spindle center to floor	mm	1030			Turret		-	Power BMT65 (12T)		
Spindle speed	rpm	3500			Tool size (OD \)		mm	25×25			
Power (continues/1 5min)	kW	15/18.5			Tool size (ID)		mm	Φ40			
Torque (continues/1 5min)	Nm	250/413			Index time (one tool)		s	0.57			
Spindle nose	-	JISA2-8			Max. drilling diameter		mm	Φ20			
Spindle bore	mm	Φ76			Max. milling diameter		mm	Φ25			
Max. Bar through spindle	mm	Φ64			Torque		Nm	23.5/35 (Rate/Max)			
					Motor						

MC function - spindle

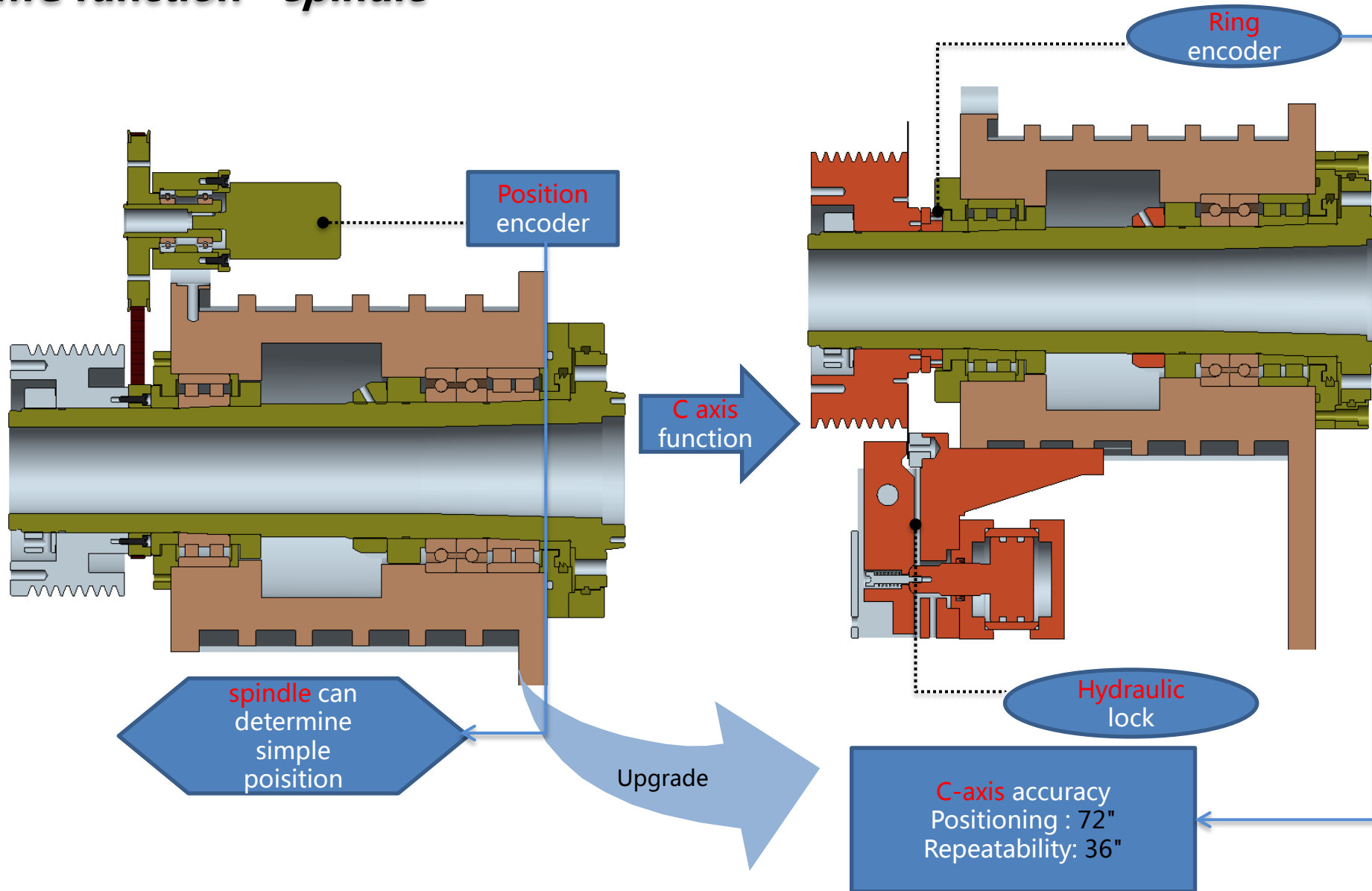

Major changes

Item	TC series	<i>With MC function</i>
Motor	β p	α p
Spindle positioning	belt drive	Hydraulic lock
X-axis servo motor	β	α
Z-axis servo motor	β	α
Sensor	Position encoder	Ring encoder
Turret	hydraulic	Servo
System	FANUC (TYPE 5)	FANUC (TYPE 1)
Min. indexing		0.01°

MC function - turret

Hydraulic turret



Upgrade

Power turret

milling function parameter

Max. drilling dia.	mm	Φ20
Max. radial tool length	mm	50
Max. rigid tapping dia.	-	M24×1.5/M16×2
Max. end mill dia.	mm	Φ25
Max. speed	rpm	4000(5min)
Motor power	kW	3.7/5.5
Transmission ratio	-	1:1
torque	Nm	23.5/35

- Power turret:
1. servo motor drives indexing and rotating of turret;
 2. C axis is driven by the **spindle motor**, with high torque and low noise;
 3. Fast and correct tool change;
 4. The power tool holder passes DIN69880 and DIN5480 standards;
 5. Repeatability: **0.003mm**;
 6. **Three-plate curvic clutch structure** ensures accurate positioning.

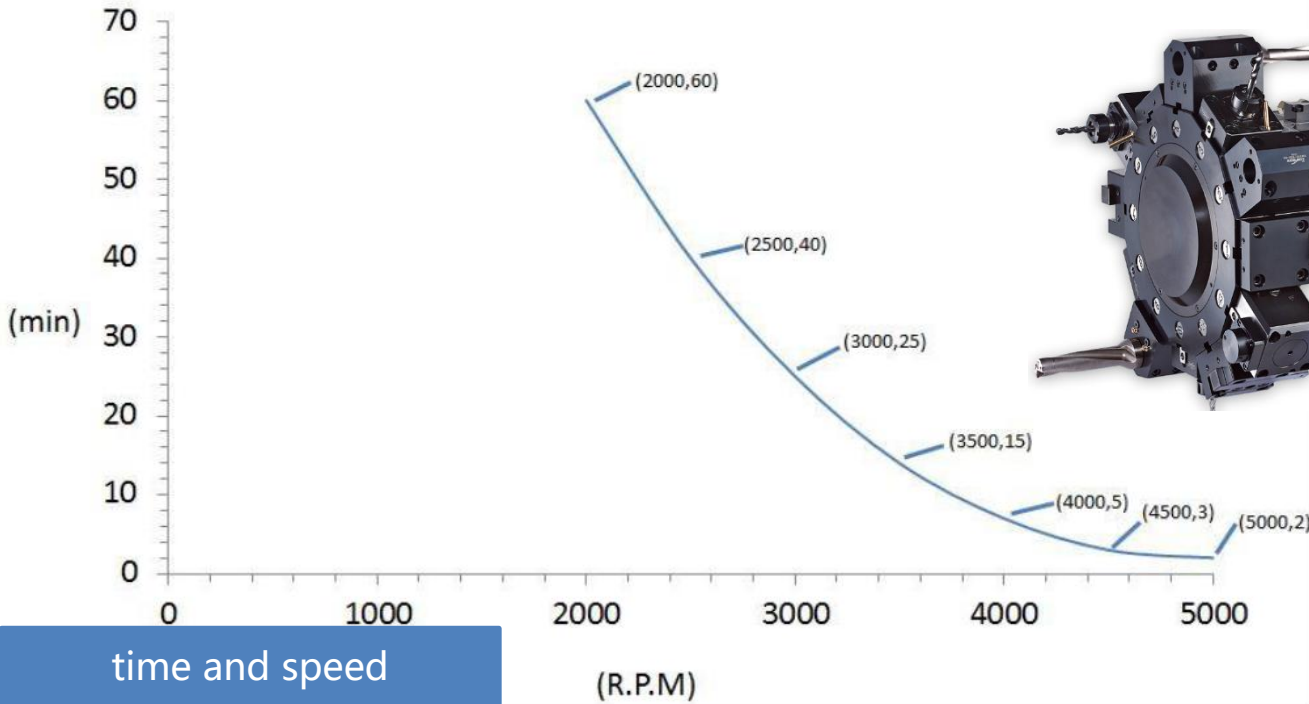
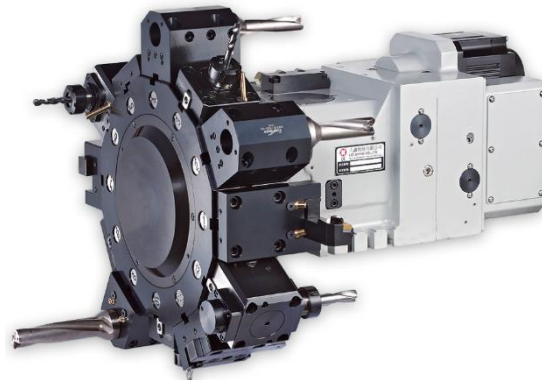

MC function-tools

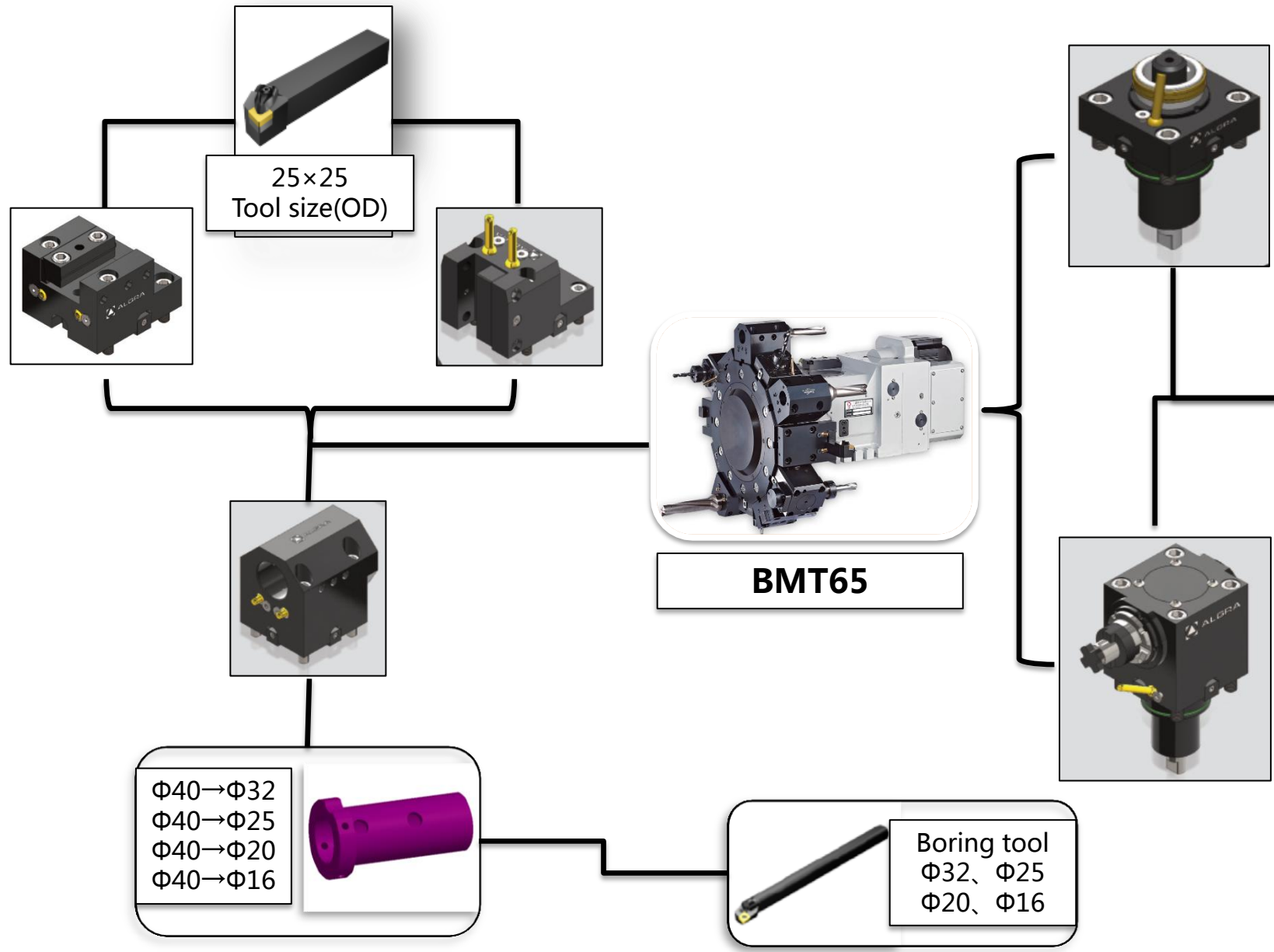

name	Dia.	QTY.
Reducer (STD)	Φ40-Φ32	1
	Φ40-Φ25	1
	Φ40-Φ20	1
	Φ40-Φ16	1

collet
ER32-6
ER32-10
ER32Φ15~ Φ16

Name (Holder)	Spec.	No
Boring tool holder (standard)	Φ40	1
End face tool holder (Standard)	25×25	1
OD tool holder (Standard)	25×25	2
Axial power tool (St.)	RAPPS40	1
Radial power tool (St.)	RRPPA40	1
Collet (Standard)	ER32-6	1
	ER32-10	1
	ERΦ15~ Φ16	1

Spindle power

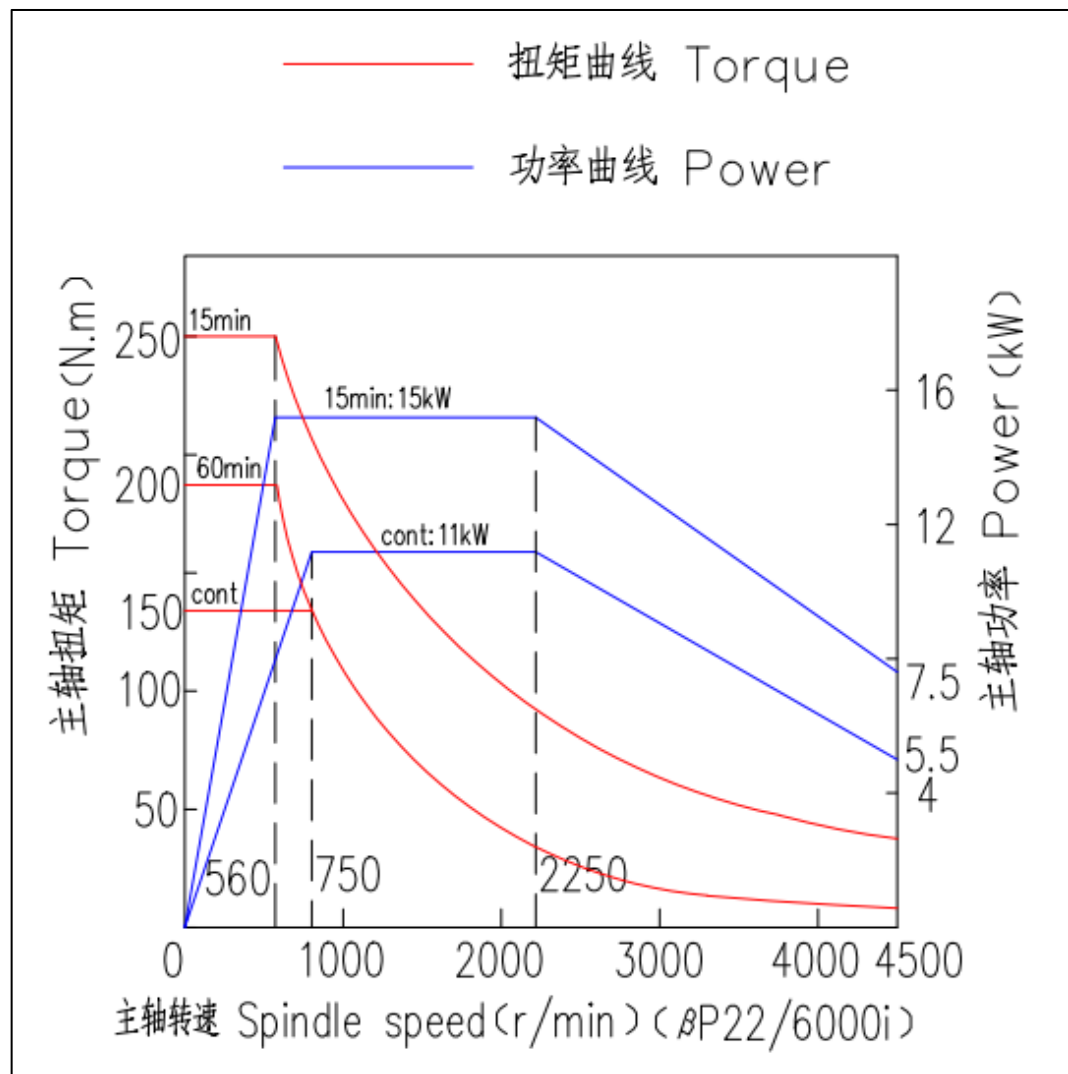

TC25II series power torque

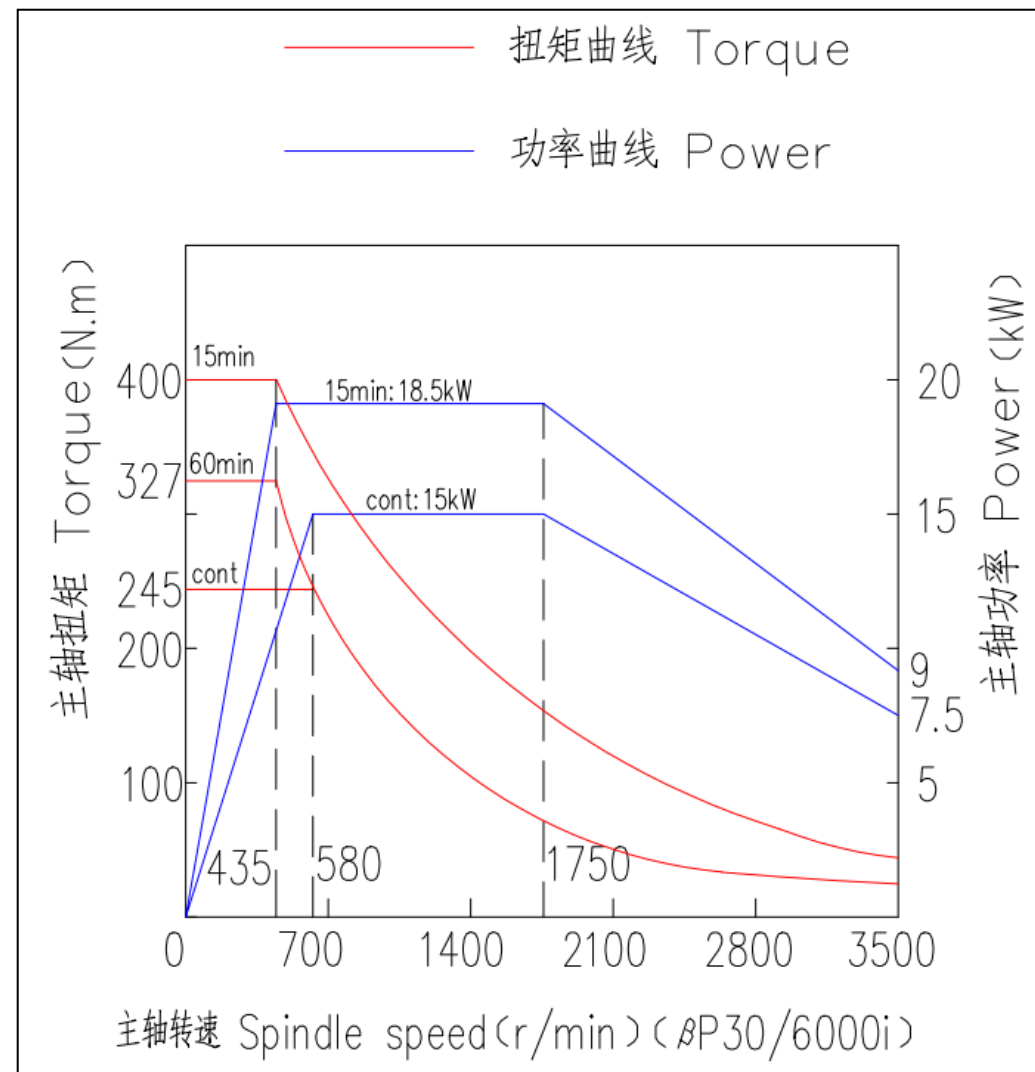

TC30II series power torque

OD turning				ID turning				U drilling			
	Unit	TC25II series	TC30II series		Unit	TC25II series	TC30II series		Unit	TC25II series	TC30II series
Material	-	45 # steel		Material	-	45 # steel		Material	-	45 # steel	
Spindle speed	rpm	965		Spindle speed	rpm	1150		Spindle speed	rpm	1000	
Depth	mm	5 (R)		Depth	mm	4 (R)		Dia.	mm	65	
Feedrate	mm/fz	0.55		Feedrate	mm/fz	0.25		Feedrate	mm/fz	0.12	
Metal removal rate	cm ³ /min	577.5		Tool length /diameter		3.5D		Metal removal rate	cm ³ /min	397.8	

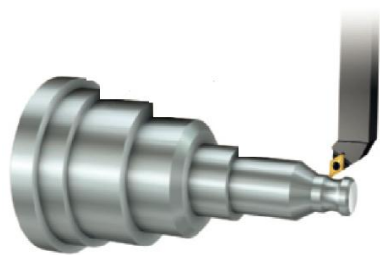

OD turning

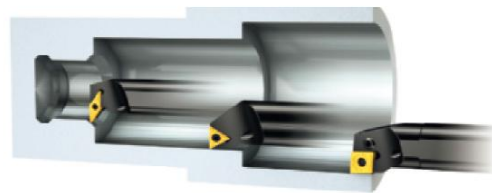

ID turning

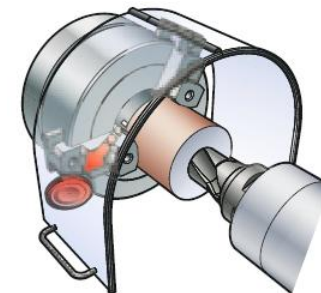

U drilling

Cutting ability

HISON

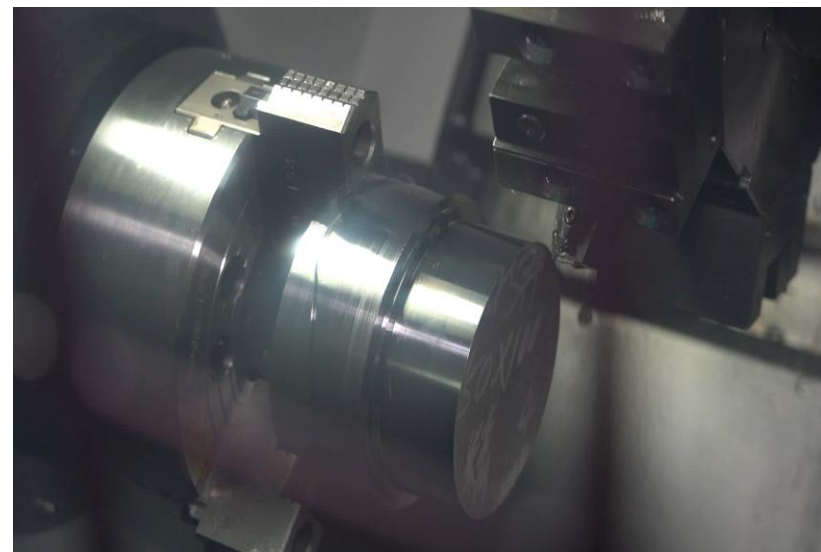

OD turning

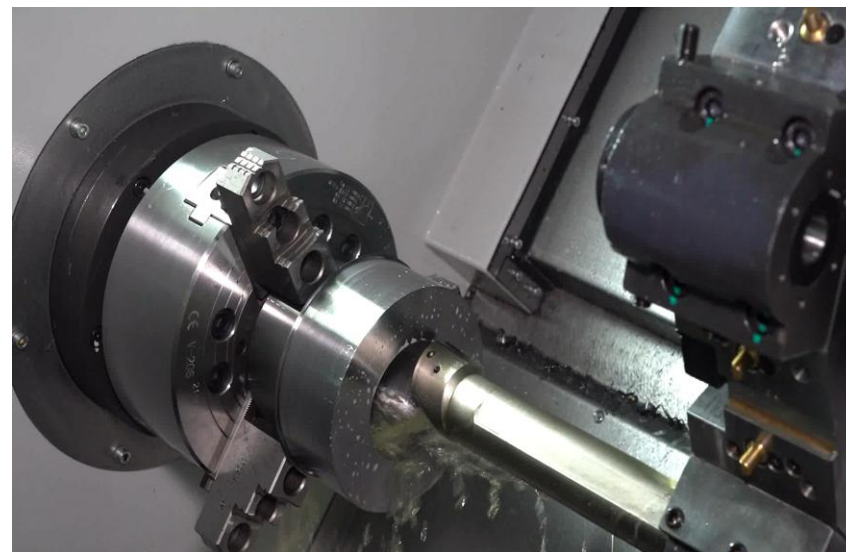

ID turning



U drilling

Processing case

Excellent performance

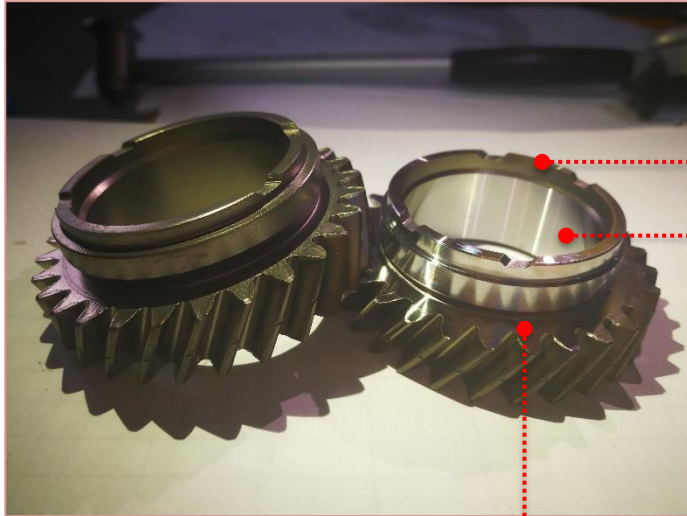

OD hard turning	$0.8/\nabla$		0.004
			0.005

ID hard turning	$0.4/\nabla$		0.004
			0.005

end surface hard turning	$1.6/\nabla$		0.03	A
			0.03	B

Sample	Hard turning after heat treatment
Material	20CrMnTi
Hardness	HRC52
Model	TC30II × 500

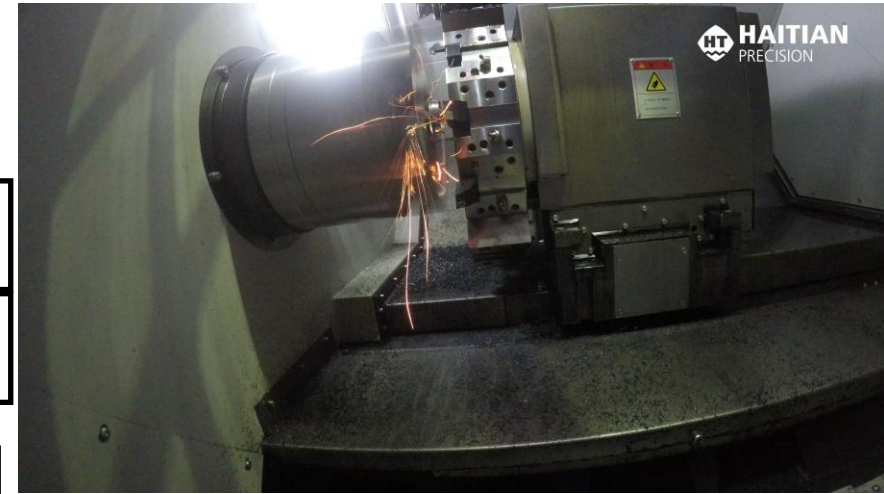

Hard turning video

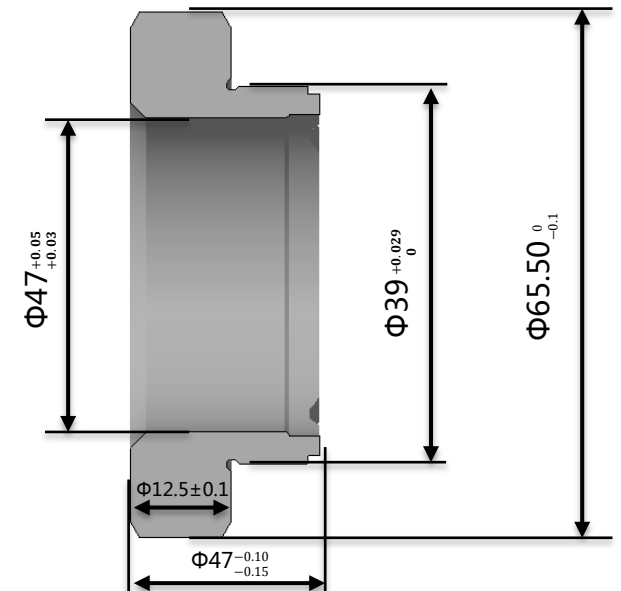



CBK stainless steel centrifugal pump
(STD)

Cooling pressure	Suitable for
0.2~0.4Mpa (STD)	Water cooling
≤ 1 Mpa (OP)	cooling through tool
≤ 2 Mpa (OP)	1. Large flow cooling 2. cooling through tool
3~7Mpa (OP)	1. Large flow cooling 2. cooling through tool 3. chip breaking

Hydraulic system

Hydraulic station parameter	
System setting pressure (factory standard)	4.0Mpa
System theoretical flow	12L/min
Oil pump motor	2.2kW-4P 380v/50Hz
Running noise	<75dB
Allowed temperature rise	15°C-45°C
Environmental temperature	-5~45°C
Environmental humidity	20~95%RH
Allowed oil temperature	0~80°C
Recommended oil	ISO VG32
Maximum pressure (adjustment range)	0~6.0Mpa

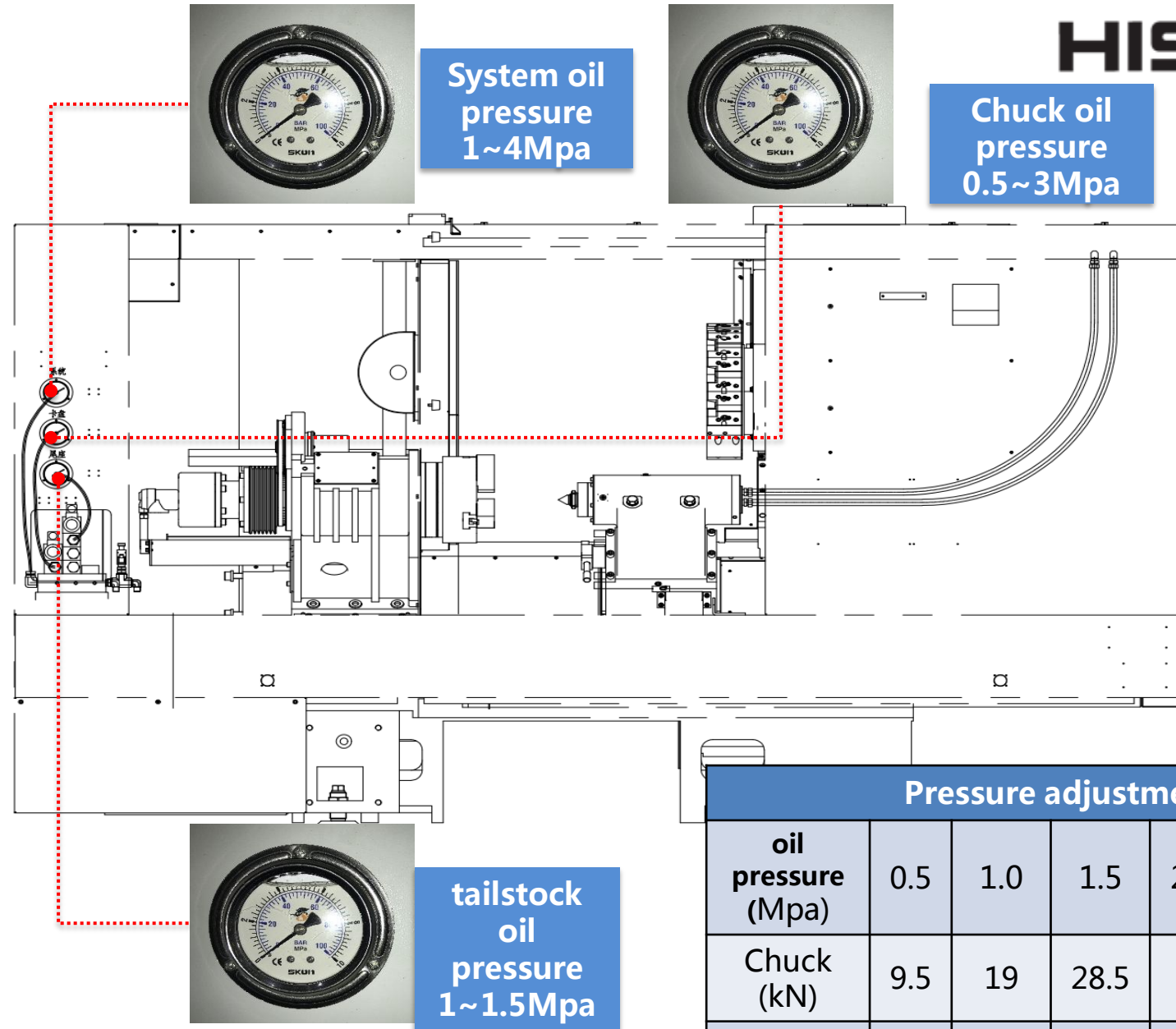

Pressure adjustment						
oil pressure (Mpa)	0.5	1.0	1.5	2.0	2.5	3.0
Chuck (kN)	9.5	19	28.5	38	47.5	57
Sleeve (kN)	-	1.59	2.39	-	-	-

Option -SMW hydraulic steady rest

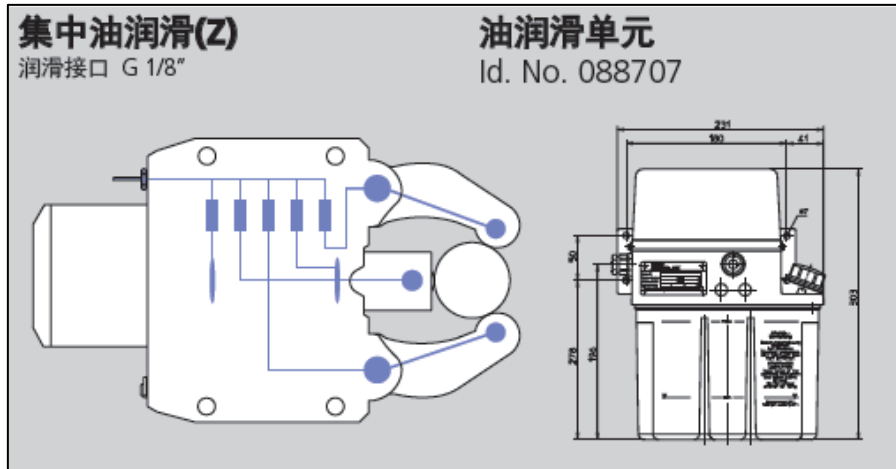

Lubrication break: 5-20 minutes
 Minimum/maximum operating pressure: 10-45bar
 Lubricating oil: viscosity ISO 46

SMW hydraulic steady rest

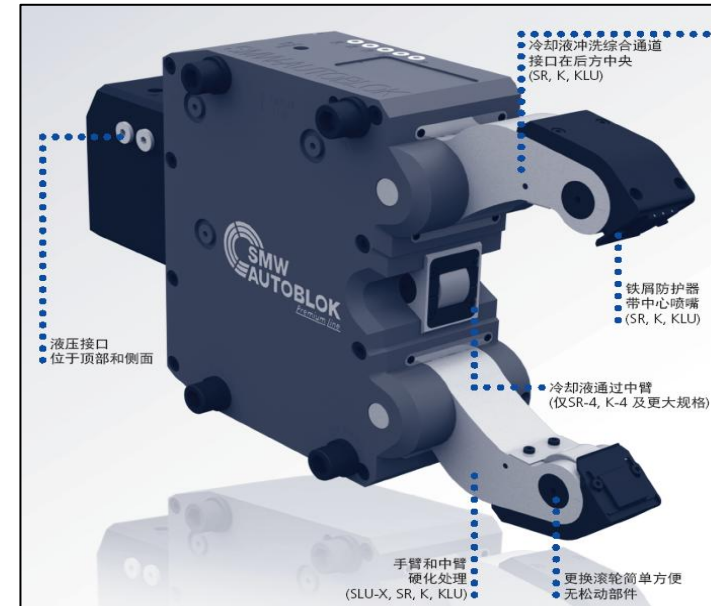

Model	unit	SLU-X3	SLU-X3.1	SLU-X3.2
Clamping Scope	mm	Φ12-Φ152	Φ20-Φ165	Φ50-Φ200
Repeatability	mm	0.007	0.007	0.007
Positioning accuracy	mm	0.04	0.04	0.04
Maximum linear speed of roller	m/min	725	725	725
Minimum/maximum working pressure	bar	8/80	8/80	8/80
Maximum clamping force	kN	10	10	10

option-autoling hydraulic steady rest

集中油润滑(Z)

润滑接口 G 1/8"

油润滑单元

Id. No. 088707

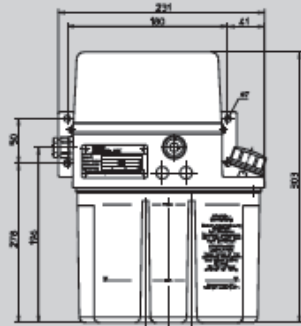
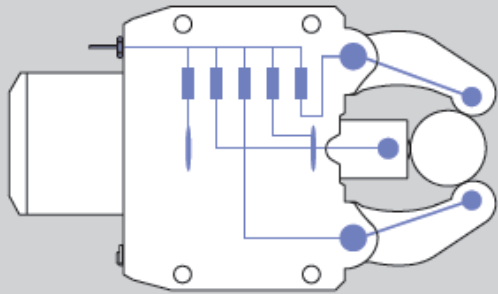

Lubrication interval is 5-20 minutes
 Minimum/maximum operating pressure 10-45bar
 Lubricating oil: viscosity 46mm /s(viscosity grade ISO)

Mold	unit	TSC-3	TSC-3.1	TSC-3.2
Clamp Scope	mm	Φ12-Φ152	Φ20-Φ165	Φ50-Φ200
Repeated positioning accuracy	mm	0.007	0.007	0.007
positioning accuracy	mm	0.04	0.04	0.04
Maximum linear speed of roller	m/min	725	725	725
Minimum/maximum working pressure	bar	8/80	8/60	8/60
Maximum clamping force	kN	10	10	10

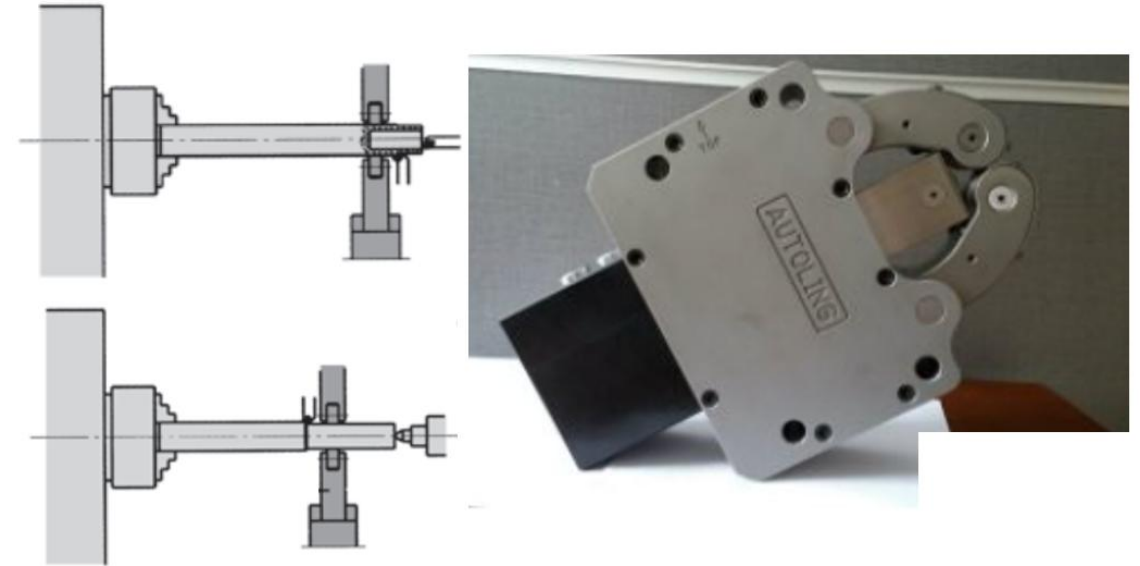









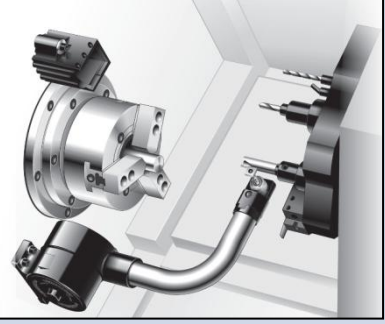

Option-bar feeder

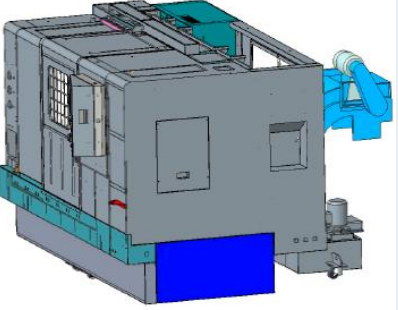

Model	unit	DH65 S2		SN542 S2/SN551 S2			
-		1.2M	1.5M	2.5M	3.2M	3.7M	4.4M
Bar diameter	mm	Φ5~Φ65		Φ5~Φ45 (SN542) / Φ5~Φ51 (SN551)			
Bar length	mm	1210	1510	2500	3200	3700	4400
Bar storage	mm	Φ5×114		Φ10×28			
length	mm	1660	1960	3250	3910	4450	5110
width	mm	1126		682			
Spindle height	mm	850~1250		900~1195			
Collet size	mm	-		50			
Machine weight	kg	298	328	800	975	1000	1125
Air pressure	Mpa	0.5~0.7					

Other options

	<p>Tool setter</p>		<p>Solid chuck</p>		<p>Hollow chuck</p>		<p>Oil mist collector</p>
	<p>Air gun</p>		<p>Rear chip conveyor only (TC25x500)</p>		<p>Oil skimmer</p>		<p>Air conditioner</p>
	<p>Solid cylinder</p>		<p>Hollow cylinder</p>		<p>Soft jaw</p>		<p>Hard jaw</p>

Notes: Pictures only for reference.

Processing scope

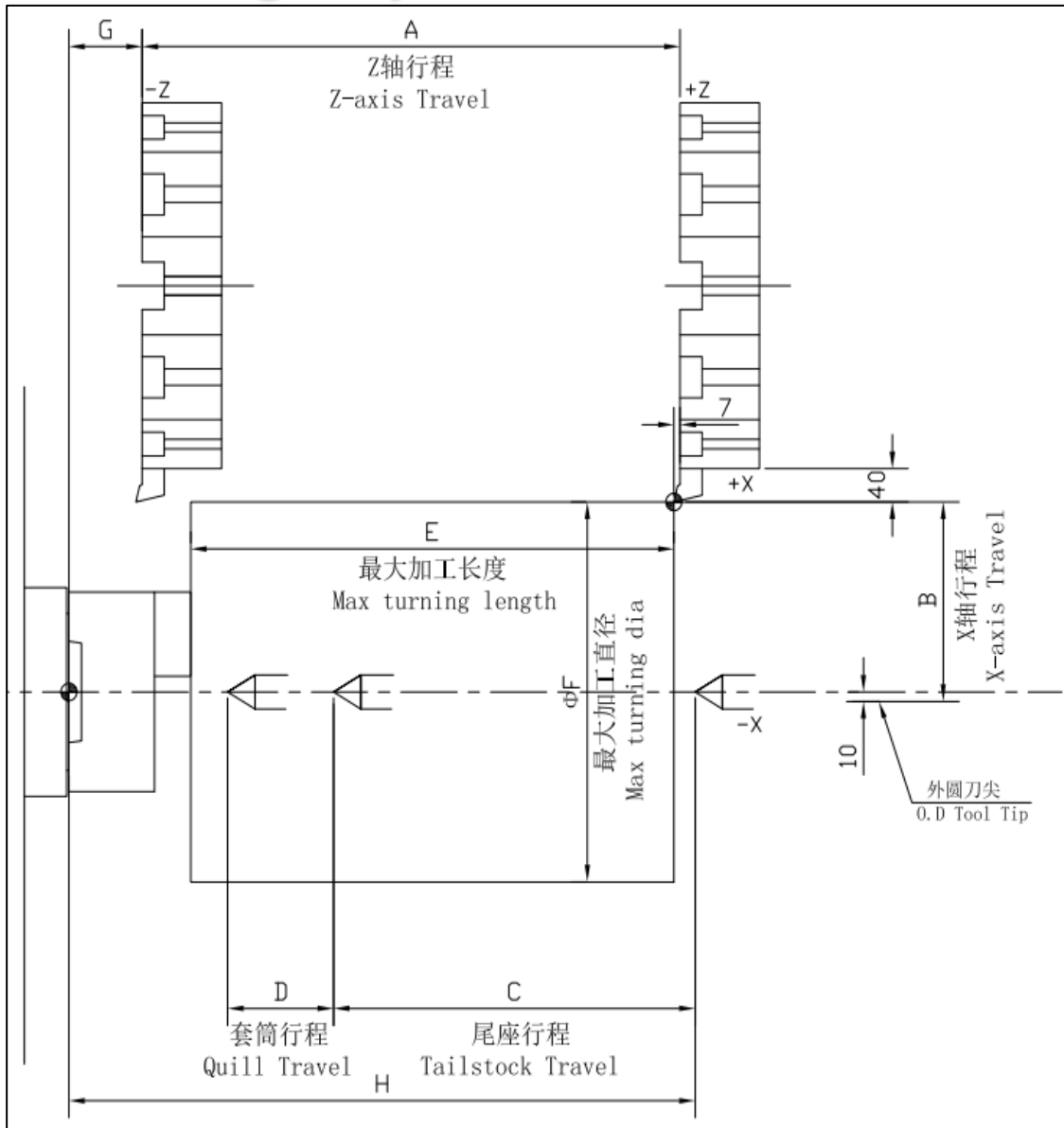

Model	A (mm)	B (mm)	C (mm)	D (mm)	E (mm)	F (mm)	G (mm)	H (mm)	I (mm)
TC25 II × 500	610	210	410	120	548	400	83	700	35
TC25 II × 1000	1050		730		1000		95	1160	
TC30 II × 500	580	260	370		500	500	87	670	40
TC30 II × 1000	1050		730		1000		105	1165	
TC30 II × 1500	1550		1100		1490		95	1700	

Turret interferogram

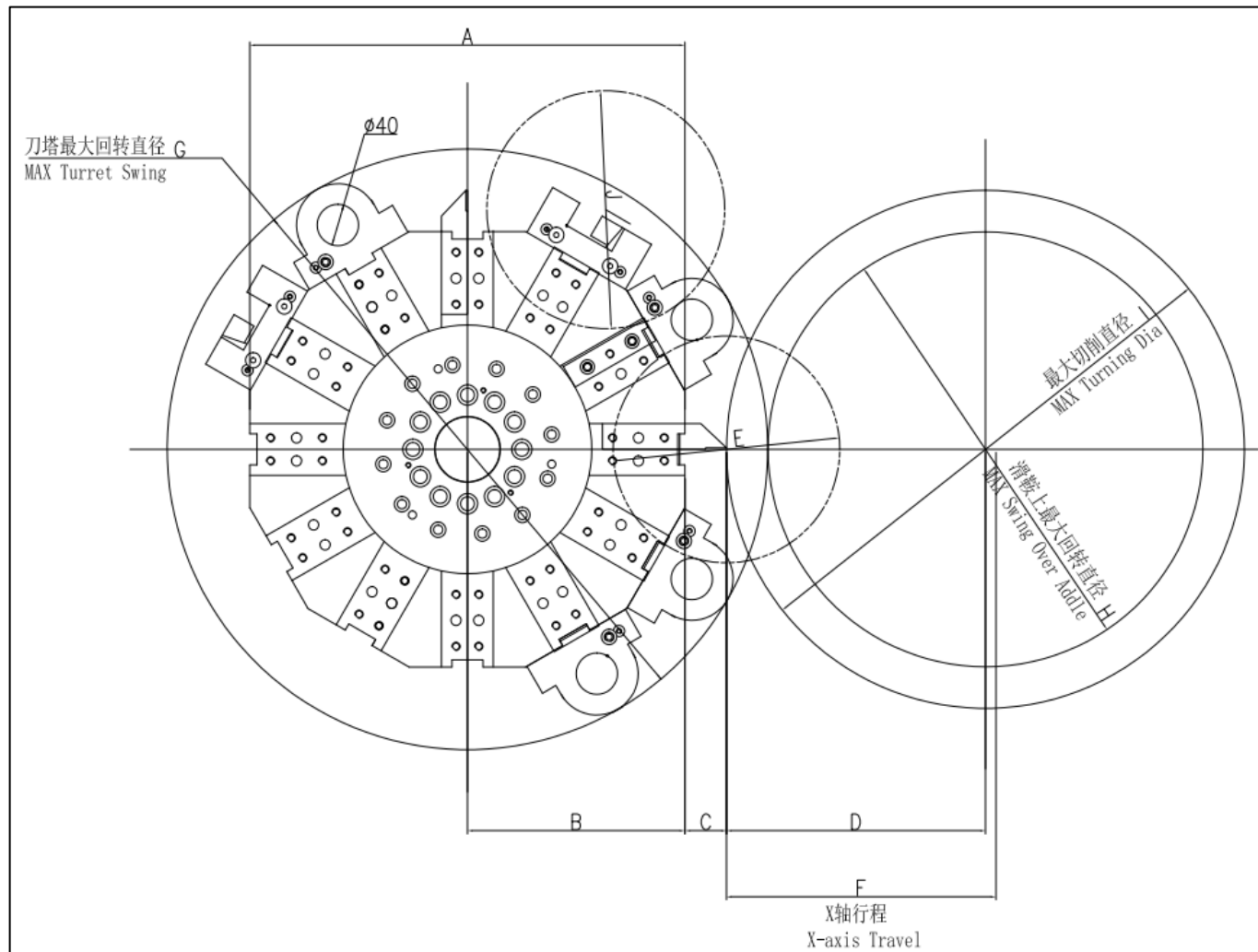

Model	A(mm)	B(mm)	C(mm)	D(mm)	E(mm)	F(mm)	G(mm)	H(mm)	I(mm)	J(mm)
TC25II series	385	192.5	35	200	$\phi 195$	210	$\phi 525$	$\phi 320$	$\phi 400$	$\phi 225$
TC30II series	420	210	40	250	$\phi 215$	260	$\phi 580$	$\phi 420$	$\phi 500$	$\phi 230$



Machine size

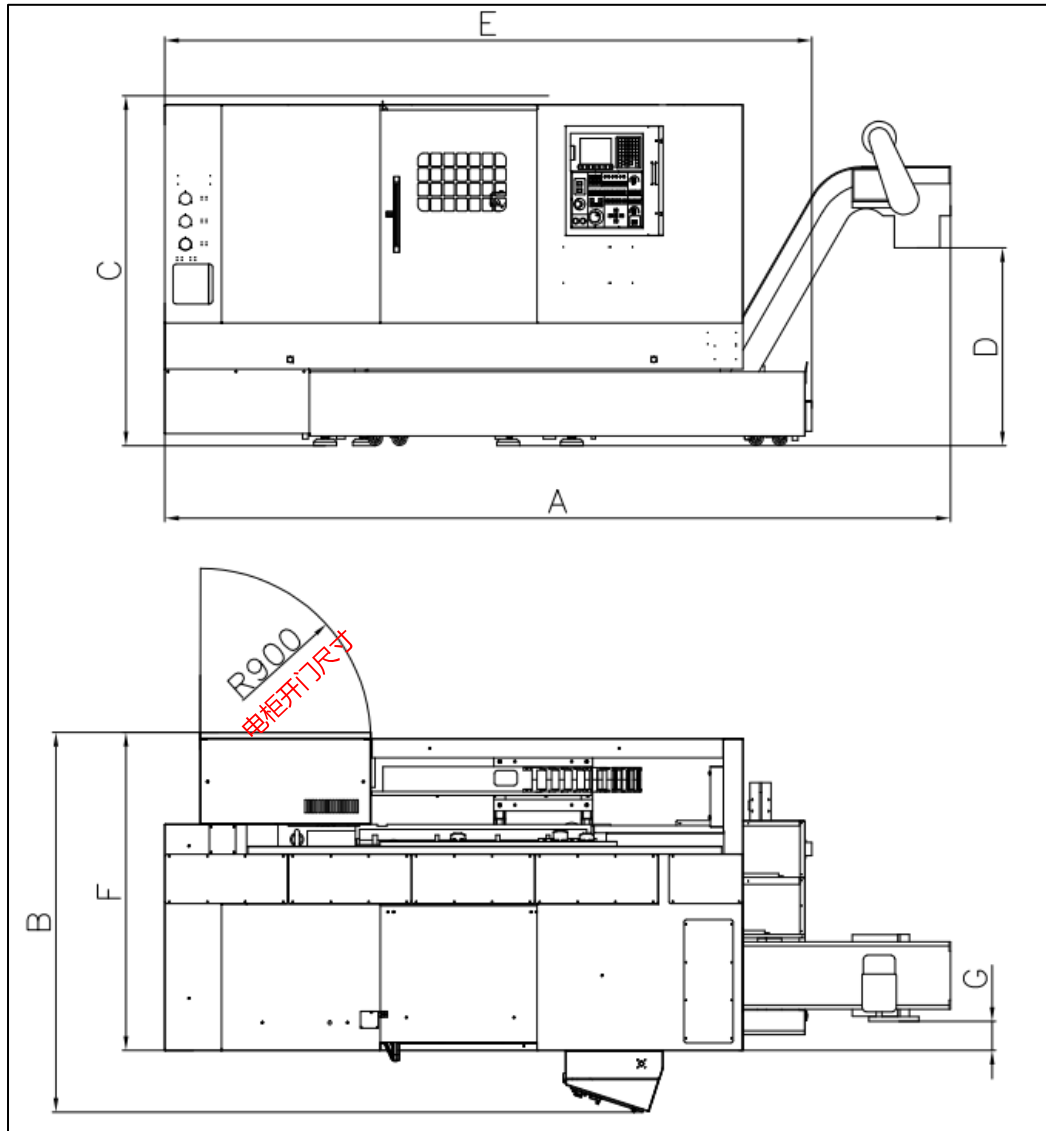

Model	A (mm)	B (mm)	C (mm)	D (mm)	E (mm)	F (mm)	G (mm)
TC25 II × 500	4200	2050	1900	1050	3415	1680	155
TC25 II × 1000	4600			1060	3725		
TC30 II × 500	4200	2050	2020	1050	3415	1680	155
TC30 II × 1000	4600			1060	3725		
TC30 II × 1500	5350				4500		



HISKIN

